

범 위	등 급			공 차		
	I	II	III	I	II	III
0 ~ 4 이하	±0.1	±0.2	±0.3			
4 ~ 16 이하	±0.2	±0.3	±0.5			
16 ~ 63 이하	±0.3	±0.5	±0.8			
63 ~ 250 이하	±0.5	±0.8	±1.2			
250 ~ 1000 이하	±0.8	±1.2	±2.3			
1000 ~	±1.5	±2.3				
경 도						
표면거칠기						

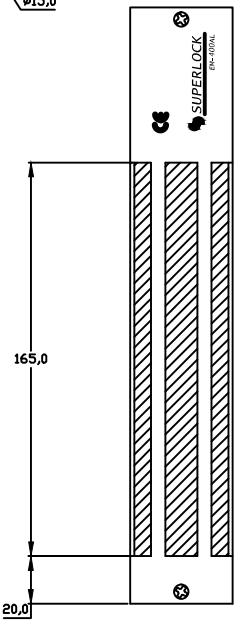
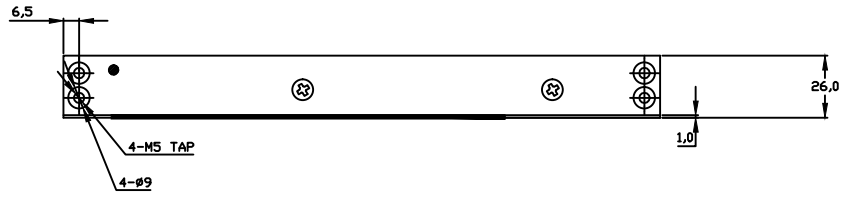
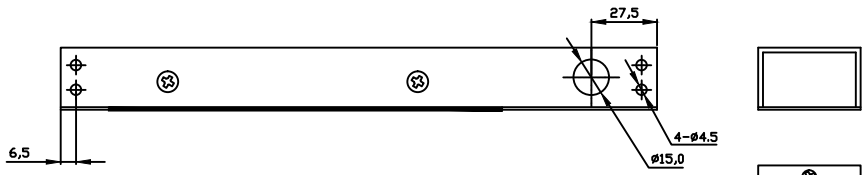
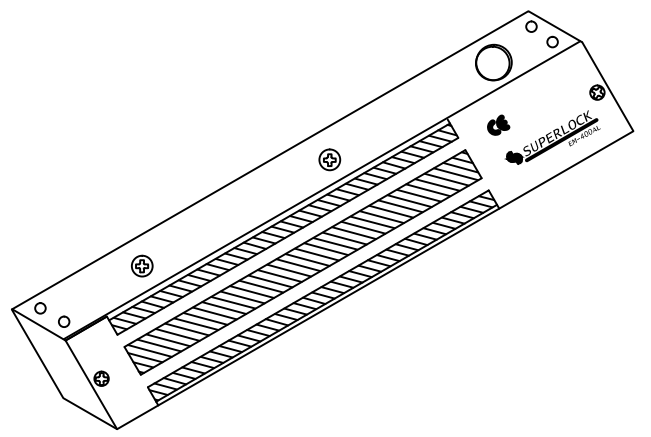
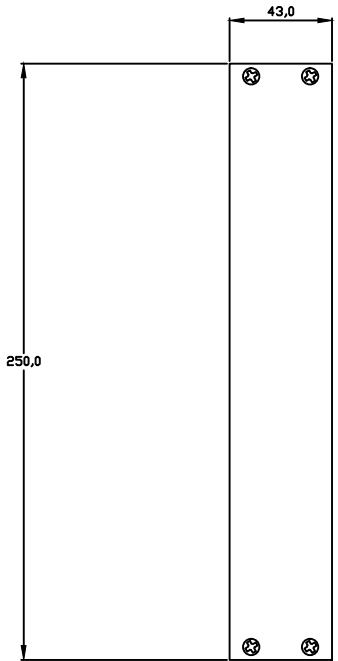

NOTE

1. -ANODIZING : SILVER / 연질 / 반광

C	B	A	NO.	DWG. NO.	PART NAME	SPEC'	MATERIAL	Q'TY	REMARK	
					▶ MATERIAL	AL6060	▶ MODEL	▶ Q'TY	▶ SIZE	A3
					▶ SURFACE	ANODIZING	▶ PART NAME			▶ SCALE
					▶ DRAWN	▶ REVIEW	▶ APPROVAL			
					Y.H.HAN	C.S.KIM	C.S.KIM			▶ SHEET
					▶ DWG. NO.			EM-400AL-001		▶ REV.
								▶ CODE		

본 체